



# V15

## Sit-Down Counterbalanced



### CAPACITY

V-15 2800 lbs. at 24" load center

### BATTERY

V-15 Battery compartment: 32" x 19" x 24"  
Minimum battery weight 1520 lbs. No cover  
Anderson 350 Blue-A22

### PERFORMANCE

48 volt batteries with 400-600 Ah capacity  
ZAPI AC lift and travel control.

### TRAVEL

9 mph empty  
8 mph loaded

### LIFT

Up to 84 fpm empty  
Up to 55 fpm loaded

### LOWERING

Up to 85 fpm empty.  
Up to 87 fpm loaded

### TIRES

FRONT DRIVE X 2  
18" x 7.8" solid pneumatic  
DUAL STEER TIRE  
15" x 4.62" solid pneumatic

### OPERATOR COMPARTMENT

Ergonomic roomy cab, wide view mast, hydrostatic power steering with spinner knob, adjustable steering column and adjustable suspension seat ensures comfortable working position. Hydraulic controls: lift/lower, tilt, and load side-shift within easy reach of operator.

Large "wide view" reversing mirror increases operation efficiency. Side hand rail aids operator comfort in reverse driving position.

### HYDRAULICS

Powerful AC hydraulic lift motor provides smooth high torque lifting and lowering. Hydraulic lift and drive components are sealed against dirt and water protecting them from contamination.

### ELECTRICAL

AC technology fitted to heavy-duty applications. Electrical current is optimized and AC motors are brushless, which minimizes servicing. "neutral braking" eliminates truck roll-back and allow higher travel speeds. Diagnostic display with thirty performance travel and lift parameters can be adjusted to suit all types of loads, working condition's area and operator driving skill.

### DRIVE UNIT AND BRAKES

Dual drive motors offer great maneuverability. The incorporation of ZF® developed components, including finely engineered helical gears, assured low noise, high quality and a long service life with low maintenance.

The "V" series three-wheel truck has three independent braking systems: regenerative "neutral braking", hydraulic wet disc braking, and toggle-type parking brake.

### FRAME AND MAST

High stability chassis with long wheel-base, wide tires and low center of gravity. "See Thru" integral side-shift with load back rest (LBR). Wide view mast, low scuttle and high seating position gives the operator an excellent view, reducing load damage and accidents. Fully enclosed chassis weldment house the dual drive motors.

### SERVICEABILITY

The state of-the-art controller can be easily accessed at waist height, reducing service time. Uncomplicated removable side battery compartment allows battery maintenance.

### STANDARD EQUIPMENT

- Headlights and Brake Lights
- Yellow Flashing Light
- Solid Pneumatic Tires
- Dual Steer Tire
- Integral Side-Shift
- Ergonomic Operators Compartment



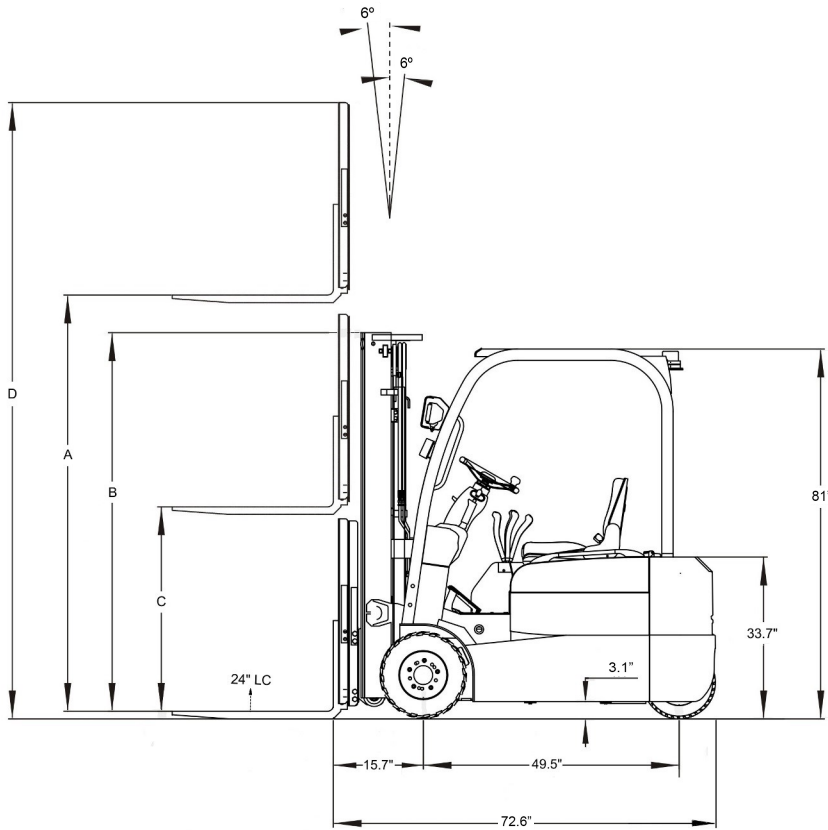

**V-15 RATED CAPACITY**

2800 lbs. to 118" @ 24" LC  
 2000 lbs. to 188" @ 24" LC

Gradeability: Loaded 10.5%  
 Unloaded 14.5%

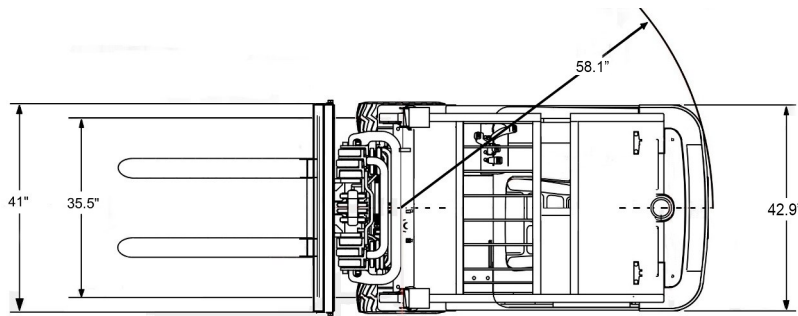

Model #	Mast	Lift Height	Col Height	Free Lift		Extended Height		<sup>3</sup> Weight (lbs)
				Without Backrest	With Backrest	Without Backrest	With Backrest	
				C		D		

**2800 lbs Capacity @ 24" Load Center**

V15-177	TriMast	177	81	58	39	198	219	6698
V15-188	TriMast	188	85	62	43	210	231	6820

<sup>3</sup>Estimated shipping weight without battery





# V18

## Sit-Down Counterbalanced

### **CAPACITY**

V-18 3500 lbs. at 24" load center

### **BATTERY**

V-18 Battery compartment: 32" x 23" x 24"  
Minimum battery weight 1520 lbs. No cover  
Anderson 350 Blue-A22

### **PERFORMANCE**

48 volt batteries with 400-600 Ah capacity  
ZAPI AC lift and travel control.

### **TRAVEL**

9 mph empty  
8 mph loaded

### **LIFT**

Up to 84 fpm empty  
Up to 53 fpm loaded

### **LOWERING**

Up to 85 fpm empty.  
Up to 87 fpm loaded

### **TIRES**

FRONT DRIVE X 2  
18" x 7.8" solid pneumatic  
DUAL STEER TIRE  
15" x 4.62" solid pneumatic

### **OPERATOR COMPARTMENT**

Ergonomic roomy cab, wide view mast, hydrostatic power steering with spinner knob, adjustable steering column and adjustable suspension seat ensures comfortable working position. Hydraulic controls: lift/lower, tilt, and load side-shift within easy reach of operator.

Large "wide view" reversing mirror increases operation efficiency. Side hand rail aids operator comfort in reverse driving position.

### **HYDRAULICS**

Powerful AC hydraulic lift motor provides smooth high torque lifting and lowering. Hydraulic lift and drive components are sealed against dirt and water protecting them from contamination.



### **ELECTRICAL**

AC technology fitted to heavy-duty applications. Electrical current is optimized and AC motors are brushless, which minimizes servicing. "neutral braking" eliminates truck roll-back and allow higher travel speeds. Diagnostic display with thirty performance travel and lift parameters can be adjusted to suit all types of loads, working condition's area and operator driving skill.

### **DRIVE UNIT AND BRAKES**

Dual drive motors offer great maneuverability. The incorporation of ZF® developed components, including finely engineered helical gears, assured low noise, high quality and a long service life with low maintenance.

The "V" series three-wheel truck has three independent braking systems: regenerative "neutral braking", hydraulic wet disc braking, and toggle-type parking brake.

### **FRAME AND MAST**

High stability chassis with long wheel-base, wide tires and low center of gravity. "See Thru" integral side-shift with load back rest (LBR). Wide view mast, low scuttle and high seating position gives the operator an excellent view, reducing load damage and accidents. Fully enclosed chassis weldment house the dual drive motors.

### **SERVICEABILITY**

The state of-the-art controller can be easily accessed at waist height, reducing service time. Uncomplicated removable side battery compartment allows battery maintenance.

### **STANDARD EQUIPMENT**

- Headlights and Brake Lights
- Yellow Flashing Light
- Solid Pneumatic Tires
- Dual Steer Tire
- Integral Side-Shift
- Ergonomic Operators Compartment



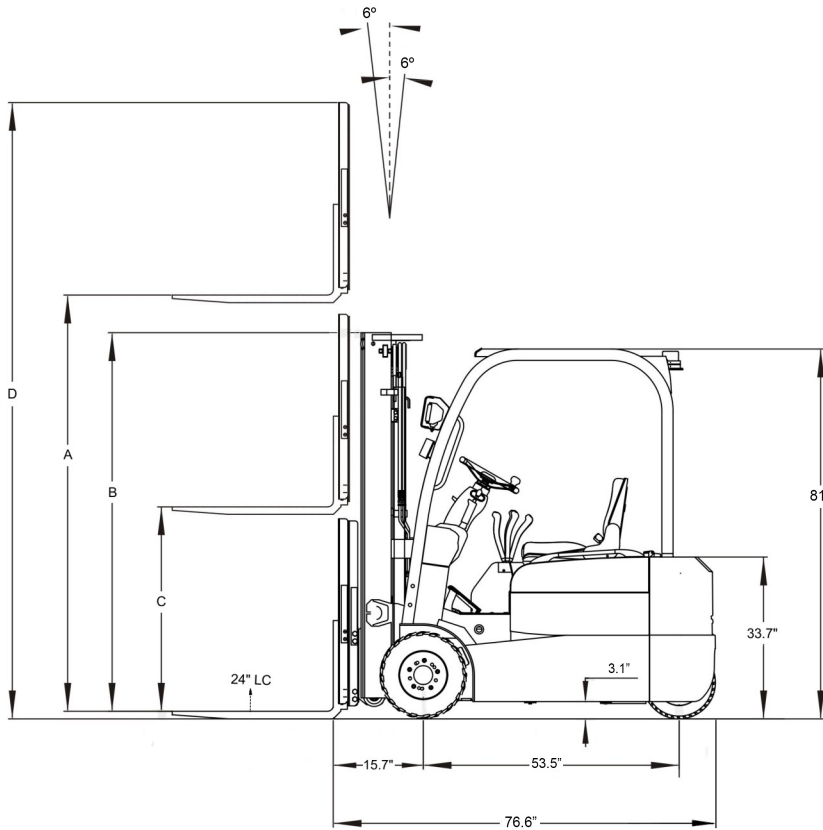

**V-18 RATED CAPACITY**

3500 lbs. to 118" @ 24" LC  
 2479 lbs. to 188" @ 24" LC

Gradeability: Loaded 10.5%  
 Unloaded 14.5%

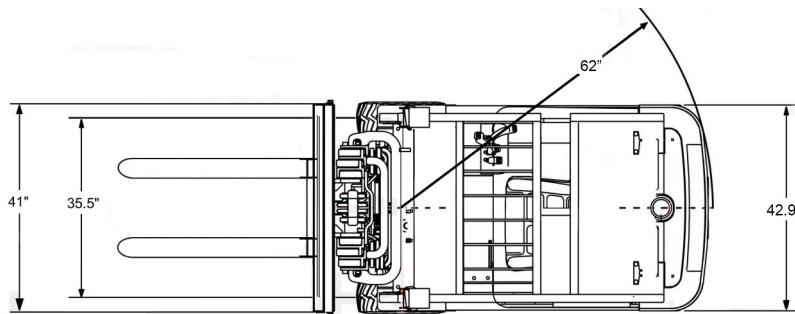

Model #	Mast	Lift Height	Col Height	Free Lift		Extended Height		<sup>3</sup> Weight (lbs)
				Without Backrest	With Backrest	Without Backrest	With Backrest	
				C		D		
		A	B					

**3500 lbs Capacity @ 24" Load Center**

V18-177	TriMast	177	81	58	39	198	219	7303
V18-188	TriMast	188	85	62	43	210	231	7425

<sup>3</sup>Estimated shipping weight without battery



# V20

## Sit-Down Counterbalanced



### **CAPACITY**

V-20 4000 lbs. at 24" load center

### **BATTERY**

V-20 Battery compartment: 32" x 28" x 24"  
Minimum battery weight 1520 lbs. No cover  
Anderson 350 Blue-A22

### **PERFORMANCE**

48 volt batteries with 400-600 Ah capacity  
ZAPI AC lift and travel control.

### **TRAVEL**

9 mph empty  
8 mph loaded

### **LIFT**

Up to 84 fpm empty  
Up to 51 fpm loaded

### **LOWERING**

Up to 85 fpm empty.  
Up to 87 fpm loaded

### **TIRES**

FRONT DRIVE x 2  
18" x 7.8" solid pneumatic  
DUAL STEER TIRE  
15" x 4.62" solid pneumatic

### **OPERATOR COMPARTMENT**

Ergonomic roomy cab, wide view mast, hydrostatic power steering with spinner knob, adjustable steering column and adjustable suspension seat ensures comfortable working position. Hydraulic controls: lift/lower, tilt, and load side-shift within easy reach of operator.

Large "wide view" reversing mirror increases operation efficiency. Side hand rail aids operator comfort in reverse driving position.

### **HYDRAULICS**

Powerful AC hydraulic lift motor provides smooth high torque lifting and lowering. Hydraulic lift and drive components are sealed against dirt and water protecting them from contamination.

### **ELECTRICAL**

AC technology fitted to heavy-duty applications. Electrical current is optimized and AC motors are brushless, which minimizes servicing. "neutral braking" eliminates truck roll-back and allow higher travel speeds. Diagnostic display with thirty performance travel and lift parameters can be adjusted to suit all types of loads, working condition's area and operator driving skill.

### **DRIVE UNIT AND BRAKES**

Dual drive motors offer great maneuverability. The incorporation of ZF® developed components, including finely engineered helical gears, assured low noise, high quality and a long service life with low maintenance.

The "V" series three-wheel truck has three independent braking systems: regenerative "neutral braking", hydraulic wet disc braking, and toggle-type parking brake.

### **FRAME AND MAST**

High stability chassis with long wheel-base, wide tires and low center of gravity. "See Thru" integral side-shift with load back rest (LBR). Wide view mast, low scuttle and high seating position gives the operator an excellent view, reducing load damage and accidents. Fully enclosed chassis weldment house the dual drive motors.

### **SERVICEABILITY**

The state-of-the-art controller can be easily accessed at waist height, reducing service time. Uncomplicated removable side battery compartment allows battery maintenance.

### **STANDARD EQUIPMENT**

- Headlights and Brake Lights
- Yellow Flashing Light
- Solid Pneumatic Tires
- Dual Steer Tire
- Integral Side-Shift
- Ergonomic Operators Compartment



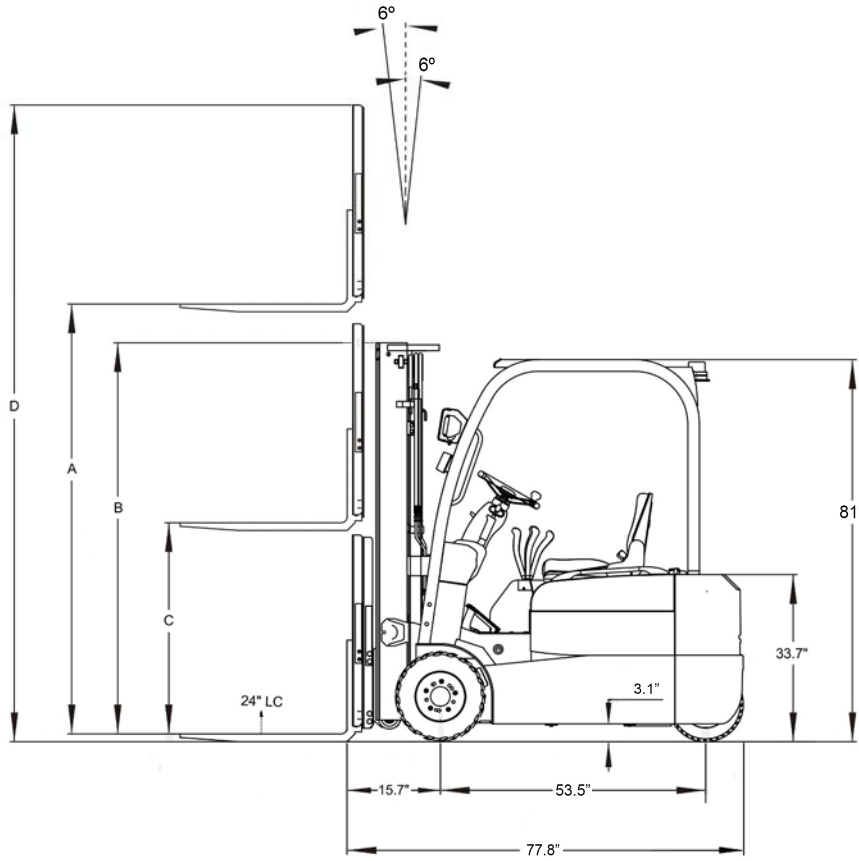

**V-20 RATED CAPACITY**  
 4000 lbs. to 118" @ 24" LC  
 2800 lbs. to 188" @ 24" LC

Gradeability: 10.5% Loaded  
 14.5% Unloaded

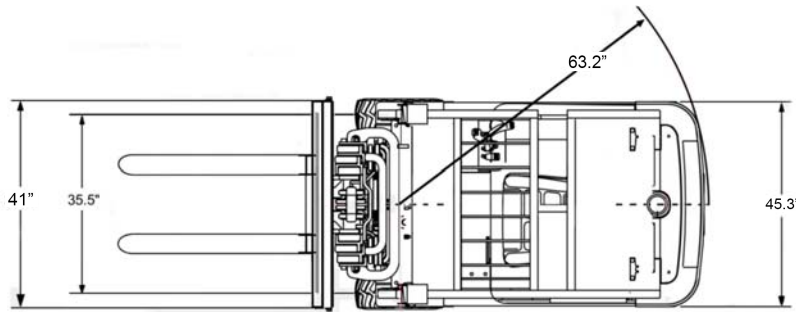

Model #	Mast	Lift Height	Col Height	Free Lift		Extended Height		Weight (lbs)
				Without Backrest	With Backrest	Without Backrest	With Backrest	
				C		D		
<b>4000 lbs Capacity @ 24" Load Center</b>								
V20-177	177	177	81	58	39	198	219	7732
V20-188	188	188	85	62	43	210	231	7854

<sup>3</sup>Estimated shipping weight without battery